



## ***SAM Weekly Newsletter - 15th March 2024***

*Biking news for ALL our advanced riders, their family and friends*

<b><i>Editorial</i></b>	<b>2</b>
<b><i>Ways to stay in touch with your Club!</i></b>	<b>4</b>
<b><i>Biking News Online</i></b>	<b>5</b>
<b><i>SAM Meetings</i></b>	<b>8</b>
<b><i>Whiteknights Blood Bikers</i></b>	<b>10</b>
<b><i>South Yorkshire Safer Roads Partnership</i></b>	<b>11</b>
<b><i>Kevin Williams</i></b>	<b>13</b>
<b><i>IAM RoadSmart News</i></b>	<b>17</b>
<b><i>Being a member of the SAM Club</i></b>	<b>20</b>
<b><i>Extra bits</i></b>	<b>21</b>
<b><i>What are we about...</i></b>	<b>22</b>
<b><i>Club Merchandise</i></b>	<b>24</b>

## ***Editorial***

As I wrote last week, I am stepping down from the SAM Committee and as a Trustee of the SAM charity. I will continue to support SAM as a volunteer to write this newsletter, maintain and develop the website and manage the Google Workspace accounts. I will only step down from these roles when the SAM Committee has suitable arrangements in place.

Last Saturday was wet and cold, but SAM members put on their thermals and rode out. We had a great time chatting about our latest life events, what was in the news and how our week was so busy that riding out was a relief. Even if you can't ride, putting the world to rights with SAM friends always feels better.

The views of SAM members on the recent management of the IAM were conveyed at a meeting with Steve Ellis (IAM Area Service Delivery Manager). We are informed that the IAM recognises the strongly expressed views of its members and is working hard toward a much better and sustainable future for the charity and its members. Just like the SAM charity, the IAM is looking to ensure that PTW (powered-two-wheel) transport is socially and politically valued; and, part of a strategic solution toward a lower carbon future. SAM members have an important role in ensuring that public education and the development of advanced riding thrives in our community. Lots of riders rely on the SAM charity to help them develop and maintain their riding skills; and, help the NHS and other worthy causes in our community.

As usual, the Whiteknights NHS Blood Bikes were parked up with us at Meadowhall Retail Park. A number of members have expressed an interest in joining the Whiteknights to support our local NHS. They are always looking for advanced riders and people to help with public education in promoting their role in delivering better health care. Spread the message.

The SAM Committee has decided to ask the Observers to suggest candidates to take over from Andy Frith as Chief National Observer. As the group of SAM members most affected by the change of leadership, the Committee has given them a chance to express their opinions. The SAM Committee has the responsibility for appointing the Chief National Observer. The person in that role also reports to the Committee on issues relating to the training of Observers and Associates. Andy has done a fantastic job and will continue in an advisory and support role to the Observers in the SAM Group.

Onto more good news this week. The FREE web hosting provided by 34SP.com has been renewed for another year. Over the past 10 years this company has generously donated FREE annual web hosting, technical management and support. This has saved the SAM charity a considerable amount of money and we are happy to reciprocate by highlighting 34SP.com on our website and in our publicity material.

Spring is here and there is additional demand on our advanced rider training. As many local motorcyclists pull their machines from the back of the shed, it's time to focus fully on what we do so well - public education and advanced rider training. Some members, including your editor, haven't ridden as much over the winter as the rest of the year. Now is the time to check your advanced rider knowledge and skills. Ensure yourself that you are still able to be an advanced rider. Recent BikeSafe data suggest that 80% of motorcyclists 'believe' they are competent riders. BikeSafe found that 96% of riders needed to improve their riding. There is no worse fool than a rider who 'thinks' they ride well, when in reality they need to ride better. SAM members riding in groups can help by checking each rider's performance. Just a thought.

As stated above, I will continue to volunteer to help the SAM charity. Some things that SAM members can do are to talk to those around you about the role of motorcycles in our community. Stress that they can be a cost-effective purchase, produce less pollution, quicker journey times, have better manoeuvrability and that 90% of components can be reused or recycled. If you want to do a bit more than talk, we need volunteers to help out at various planned events. This might include talking to the public about our advanced rider training, handing out information material, or being a 'meeter and greeter' to ensure that visitors feel welcomed. We have a full Club Night speaker calendar through to September, but there may be other events you want to happen. Think about it and let a member of the Committee know. Thank you.

The SAM Committee decided that it should be up to members how much the membership fees should be in the next year. We conducted a survey giving various options. 61% of members completed the survey. 70% of respondents agreed to an increase in the SAM membership, giving the Committee a clear mandate to revise the membership fee. The Committee has agreed with the majority of members that the SAM membership fee should increase to £15 (for IAM members) and £25 (for non-IAM members). *[For members paying by Standing Order please ensure that your SAM membership is adjusted accordingly.](#)* Thank you to all SAM members who took part in the survey, your help is very much appreciated in securing the future of the SAM charity.

The closing date for entries to the **SAM Annual Photo Competition** is 12mn on 20th March 2024. Make sure that your best biking pictures are sent to [sam-editor@iam-sheffield.bike](mailto:sam-editor@iam-sheffield.bike). Any entries after this date will not be accepted.

The closing date for booking the [FREE SAM Spring Breakfast](#) is 12mn on the 28th March 2024. This event is kindly sponsored by [Supremecoat Limited](#), so make sure that you order your choice or

sausage or bacon sandwich. (Mine's sausage!) The event will take place at the [Supremecoat Limited premises](#).

There is a lot more to read in your brilliant SAM newsletter this week. Happy reading!

---

## ***Ways to stay in touch with your Club!***

It's really easy to stay in touch with your Club! We provide emails, a website and use social media accounts for you to contact us. All of which is free of any cost to the Club. If you are not getting the Club information circulated, or simply want to tell us something, ***just let us know*** at [sam-editor@iam-sheffield.bike](mailto:sam-editor@iam-sheffield.bike). We'll be happy to ensure that we stay in touch with you. You can also now sign up for Club emails on the [SAM website](#). Paul Conway  
Editor & Webmaster, Sheffield Advanced Motorcyclists

## Biking News Online

### General news



#### 7 of the most reliable second-hand scooters

When buying a scooter, you don't always have to buy from new. In fact there are many second-hand scooters that are more reliable than you may think, ultimately saving you money. Here we

examine seven of the most reliable you can buy that are perfect for commuting to work or using as a daily runaround. [Read more](#)

#### [Yamaha Electric Motocross Bike Patents Battery-powered crosser based on TY-E trials machine with some key changes.](#)

The conversation never ends when it comes to motorcycles, so whether or not a motorcycle manufacturer just announced its sales numbers for the year, a custom bike was shown, or the dates for a motorcycle show were just announced, you can bet the Cycle World staff has all of the details. Stay tuned for all of the buzz as it relates to the sportbike, dirtbike, cruiser world, and more. [Read more](#)

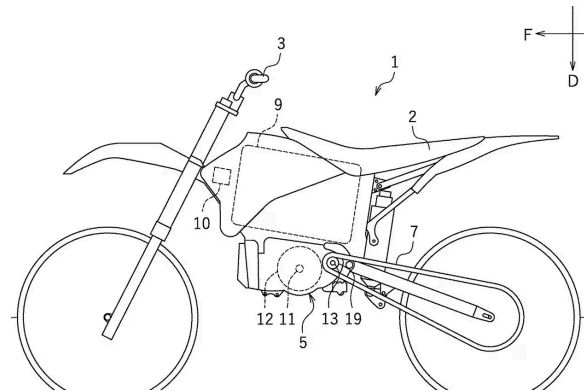

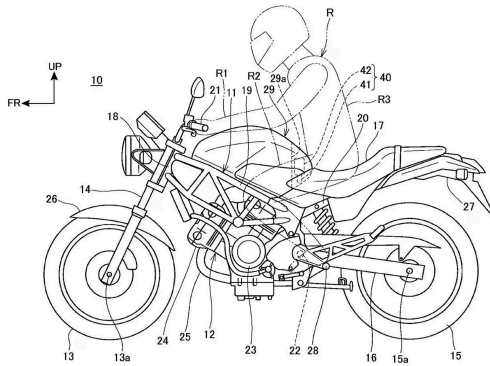

## Honda Airbag Evolution Continues

Patent shows details of potentially lifesaving technology.

Like [ABS](#) and [traction control](#), airbags are one of those safety aids that first got a foothold in cars, and which manage to be unobtrusive. Unlike safety ideas

that require the user to proactively buy into them such as seatbelts in cars, for instance, or [helmets](#) for motorcycles, car airbags are something we can simply take for granted right until the moment you need them. [Read more](#)

The driving force behind the Imps display team, who's helped countless kids reach new heights. Saffron WilsonRoy Pratt MBE 84, British, founder of the Imps Motorcycle Display Team. The Imps are a charity organisation that takes children from the ages of 5-16 and teaches them how to ride, perform and develop themselves. Roy Pratt is a true legend. With their distinctive red tunics and white helmets, the Imps Motorcycle Display Team have been a familiar sight at events, pageants and on TV for over 50 years. [Read more](#)





Electric featherweight | French trials gurus bring ultra light EM Escape enduro bike to market

French manufacturer Electric Motion are branching out from their usual remit of high-quality [battery powered trials bikes](#), to create a road-legal enduro

aimed squarely at tackling the harshest terrain. The EM and appears to blur the lines between extreme play bikes, such as KTM's Freeride EXC models, with that of more [conventional enduro machines](#). [Read more](#)

[How Motorcycle Riders Beat the Winter Blues](#). A steady Oregon rain didn't stop motorcycle enthusiasts from showing up in droves for the first-annual Cherry City Classic. Motorcycles stretched from end to end of the cavernous Jackman-Long Building in Salem, vendors like Timber Town



[Harley-Davidson](#) and moto artist Tony Morgan surrounded its perimeter, and a slew of tattoo artists clustered on one end. From a restored 1948 panhead barn find to a heavily patinated 1935 VLD, [vintage motorcycles](#) were well represented at a diverse and eclectic show. [Read more](#)





### [Biker Dating Secrets: How to Make a Biker Happy](#)

Biker dating can be a joyful experience. What could be more romantic than roaring off into the sunset on a shared adventure for two? But biker

dating is a little trickier than normal dating. I've talked about why a lot. For example: [Biker Dating is Not Like Regular Dating! \(Here's why\)](#) ...and... [Dating a Biker Can Surprise You...](#) Now, as we know, a happy biker is a lot more fun than a grumpy biker. Luckily, it's not that hard to make a biker happier. [Read more](#)

My 5yr-old Daughter Loves Her Kawasaki Elektrode, Not So Much The Razor MX350. She knows what she likes. Last spring, my daughter asked me when she could get her own motorcycle. I replied when she could ride her bicycle without training wheels. Little did I know she'd take that as a challenge and learn how to ride the bicycle in less than three days. [Read more](#)



### ***Safer riding***



What Should Be Standard On More Motorcycles? – Question of the Day. Last month, we asked for our Question of the Day whether people [expect anti-lock brakes to come standard on all](#)

[streetbikes](#), or perhaps offered as an option. There were some good responses to that, both for and against ABS, but it brought a related question to mind: what should be offered as standard equipment that currently isn't standard on all motorcycles? [Read more](#)

Recall: BMW Recalls 2024 R 1250 RT, K 1600 GT/GTL/B

Front Spring Struts May Fail Due to Lower Quality Valve Material



- BMW is recalling certain 2024 R 1250 RT, K 1600 GT / GTL / B models over front spring struts
- An estimated 80% of the 191 recalled models are estimated to be affected by this faulty part
- BMW will take care of the faulty component free of charge.
- There is no potential for reimbursement since these machines qualify under the BMW New Vehicle Limited Warranty program
- Owners will be notified around or on April 22, 2024
- Dealers were notified around or on March 1, 2024

[Read more](#)



Riding Your Motorcycle in Sunglasses: Everything You Need To Know. Riding a motorcycle is an exhilarating experience, but safety is key for ensuring a smooth ride. Motorcycle gear like a helmet, a heavy-duty jacket, gloves, boots, and more are essential for protecting you on the road. However, eye protection is just as crucial when riding a

motorcycle and is not to be underestimated.

[Motorcycle-associated ocular injuries](#) can potentially lead to vision loss and blindness, which cut your riding days short and make your daily life much more difficult. [Read more](#)

## ***Touring & Adventure***

MOTORCYCLE TRAVEL:  
Minding the pennies

Budget travel can be tricky. But if you already own a bike and you're happy to be flexible, there're lots of ways you can save cash when you're out exploring, without compromising your experience. Editor Ross tells us how...[Read more](#)



Beyond the Bungee: Modern Tie-Down Options.

Have you ever struggled to secure something to your motorcycle? I sure have. Here's my story of shame. About 13 years ago, I took my BMW F800GS on a tour through Utah. Prior to the trip, I'd purchased an ultralight backpacking tent. My budget was tight, so I used bungees to secure the tent and luggage to the passenger seat. I'd heard about Rok Straps supposedly being better than good-ol' bungees, but I put off that purchase until later. That was a mistake. Somewhere on Interstate 15 leaving Utah, my dollar-store bungees shifted and came loose—whereupon my tent became a permanent part of the Utah landscape, never to be seen again. [Read more](#)

Mystical, Magical Colombia  
Colombia is a troubled yet enigmatic country that has struck fear into the hearts American travelers for decades. A country of exotic extremes, renowned for its coffee, its beautiful women, and for its violent past. A country that until recently wasn't well known even to its inhabitants because travel within her borders was too dangerous. Unbeknownst to me at this moment, Colombia's charms will become the highlight of my journey through Latin America. [Read more](#)



**[Itchy Boots](#)** Since last week, Noraly has travelled across the Angola-Zambia border. When asked by the hotel clerk, "Where are you going?". Noraly replies, "I'm riding to Zambia, do you ever travel across the border?" The clerk replied, "Never! We fly, the roads are terrible!" Watch the last two episodes, there are some hair-raising, heart-in-the-mouth moments; and, that is just for the viewer!

**[Freddie Dobbs](#)**: Is in Mumbai. He warns every traveller to take toilet paper, be wary of the food eaten and water drunk. After a night on a bed with an MDF mattress, he takes a tour of streets looking at all the bashed up Royal Enfields.

## ***History & Custom***



[THE NUT KWAKA: A KAWASAKI W650 HARDTAIL BOBBER BY DEUS](#)

4 DAYS AGO / [22 COMMENTS](#) / [CUSTOM MOTORCYCLES](#)

In Jeremy Tagand's early days as the resident wrench at Deus ex Machina Australia, the Kawasaki W650 was his bread and butter. Deus was one of the first shops to popularize the W650 as a custom project donor, demonstrating its versatility by customizing it repeatedly across a broad spectrum of styles. This particular Kawasaki W650...[READ MORE](#)

[Slow Burn Revival: music on wheels](#)

A unique custom bike inspired by James Hetfield's carby Game Over Cycles Inspired by James Hetfield of Metallica and his 1936 Auburn 852 Boattail Speedster "Slow Burn" is a custom bike



envisioned as a sister vehicle to the classic car belonging to the famous musician. The body lines of the motorcycle exactly mirror the shape of the Slow Burn, and its construction echoes the components of the car. The motorcycle will have its premiere on March 9, 2024 in the USA at the Rat's Hole Custom Bike Show, a construction competition organized by Daytona Bike Week 2024, one of the largest motorcycle rallies in the world held annually in Florida. Click here to read this photo feature on Bikernet.com

[Read More](#)



Effie Hotchkiss and Riding Across the Country

A daughter and mother's inspiring 1915 cross-country motorcycle journey. Amid the women's suffrage movement—five years prior to the ratification of the 19th

Amendment—daughter-mother duo Effie and Avis Hotchkiss took a journey that would cement them into motorcycling’s history as the first women to take a motorcycle/sidecar across the US and back. On May 2, 1915, these two women departed Brooklyn, New York, for the Panama-Pacific Exposition in San Francisco, aboard a sidecar-equipped 1915 [Harley-Davidson](#) F-11 motorcycle. According to the 1916 Harley-Davidson Enthusiast, Effie stated, “We merely wanted to see America and considered that the three-speed Harley-Davidson for myself, and sidecar for mother and the luggage [were] best suited for the job.” [Read more](#)

---

## *SAM Meetings*



***SAM Club Saturday Meetings, Meadowhall Retail Park  
9am every Saturday throughout the year.  
Come and join us - you know you want to ride!***



Next SAM Club night: **8th April 2024 meet at 7.30pm for an 8pm start at [Treeton Miners Welfare, Arundel St, Treeton, Rotherham S60 5PW, UK](#)**  
***ANNUAL GENERAL MEETING***



Always carry your ***FREE Biker I.C.E. Card***. It gives emergency services staff vital information about the right treatment for you, should you be involved in an accident. Don't forget to update it if your health and/or social circumstances change. *SAM Club - dedicated to helping YOU to be a safer rider.*

## ***SAM Club News***

**SAM Annual Photo Competition** - Closing date: 12mn 20th March 2024

**Spring Breakfast Booking** - Closing date for [booking a place](#): 12mn 28th March 2024.

**SAM Annual General Meeting** - Meet 7.30pm for an 8pm start, [Treeton Miners Welfare Club](#), Arundel St, Treeton, Rotherham S60 5PW. Please make an effort to attend and have your say about the future of your club. Thank you.

---



## Whiteknights Blood Bikers

Whiteknights Yorkshire Blood Bikes would like to hear from people who are able to become volunteer fundraisers for this vital charity that benefits patients in Yorkshire.



Please get In touch. Even if you can only spare an hour to volunteer for us - we really need people to help us. Hope to hear from you soon.

Message us through Facebook or email:

[fundraising@whiteknights.org.Uk](mailto:fundraising@whiteknights.org.uk)

We have another Advanced-Qualified rider starting volunteering with Whiteknights West Yorkshire this weekend. Welcome to Stu Sirrat - ride safe.



262 Jobs completed



248 Urgent Jobs  
3 Emergency Jobs  
11 Relay Jobs  
0 non-urgent jobs



The time donated is an average saving to the NHS of approx. £12,711.29 over the Month



7864 Miles Ridden/Driven  
444 Hours on call

Just some of the Items we have transported this year



7 - Breast Milk



180 - Bloods and Other Samples



2 - FMT Samples



1 - Fluids



72 - Pharmacy Items and Patient Records

Vehicles Sponsored by:



We maintain the service 365 nights a year, and weekend and Public Holiday daytimes. This is a 100% volunteer service provided at no cost to the NHS

Registered Charity No. 112451

## South Yorkshire Safer Roads Partnership



BetheBest – we have created a generic logo to encourage all riders to take additional training in one format or another; such as IAM, BikeSafe or ERS. The new logo and #BetheBest tagline has been printed on promotional snoods to promote the campaign ([available at SAM Club Nights](#)). The snoods have been produced in a series of different motorbike brand colours, (Red, Orange, Green and Blue), to test if this approach is more appealing to riders.

Some really interesting debate and insight into [#activetravel](#) - in particular around increasing the number of journeys done on foot.

We discussed the barriers, benefits and beauty of walking. For a little treat, keep scrolling to see the winner of the cutest companion 🐕

[#walkingsummit](#)

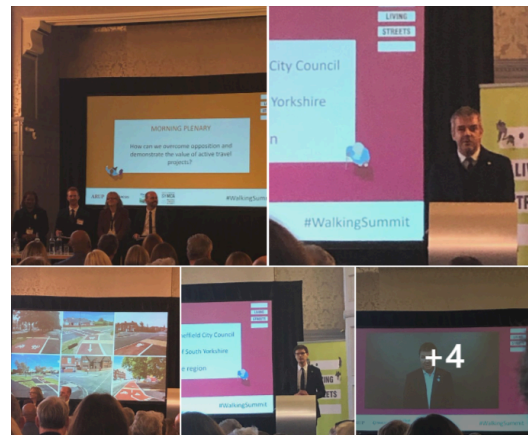

From engineers & planners to emergency service staff and educators, we all share the same goal of preventing collisions and the devastation they cause. [#roadsafety](#) [#internationalwomensday2024](#) [#barnsley](#) [#Doncaster](#) [#rotherham](#) [#sheffield](#)

## Kevin Williams

For many years road safety experts, police and motorcyclists have known that the most common collision between a motorcycle and another vehicle happens when the motorcyclist has right-of-way and another driver turns into the rider's path. All the way back in 1977, US researcher Harry Hurt stated:

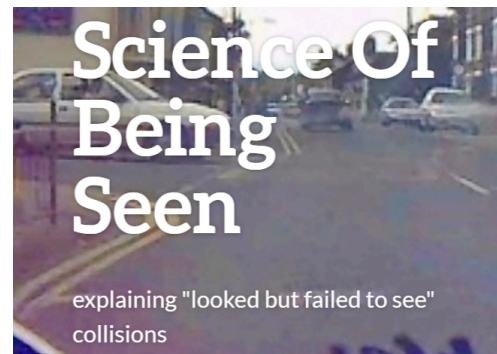

*"The most likely comment of an automobile driver involved in a traffic collision with a motorcycle is that he, or she, did not SEE the motorcycle..."* [Read more...](#) Also, see all Kevin's posts at [ko-fi.com/survivalskills](http://ko-fi.com/survivalskills).

### LAST WEEK'S ROUND-UP



Elevenses 412 Mon 4 Mar - motorcycle news, tips & views in today's show... Hairy Biker Dave Myers dies... CHiPs officer who killed pedestrian should not have been riding... pair jailed for death of rider hit

by their van's trailer... National Accident Helpline spokesperson misuses RAC stats... Yamaha breaks up the conventional production line to achieve small volume production... in-depth today - BikeSafe stats say 81% of bikers rate themselves competent or advanced but 96% 'need further development; what might that be telling us? [Watch here](#)

Newbie Mistakes #15 Watch out for Walkers. Seeing as we're sharing the road with them every single day we ride, it's a bit of a mystery why we have so much trouble dealing with people walking on them. I still recall one rider picking up a fail on test when caught out by pedestrians stopping into the road where he wasn't expecting them to cross the road. So, here are some tips for dealing with people walking in the road. [Read more](#)



Eleveses 413 Wed 6 Feb - motorcycle news, tips & views

in today's show... motorcyclist jailed after fatal crash on group ride... Axa pulls out of motorcycle insurance market... motorcycle roadworthiness tests

in France are go... US recalls AGV Tourmodular helmets for buckle problem... Michael Dunlop passes his bike test... chrome loses its shine for EU... does CFMoto 650 slip-on exhaust imply UK rider acceptance... Husqvarna shows off new 801 twin... in-depth today - delivering insight, not over-confidence...[Read more](#)

How many times? GAPS=TRAPS

"Not a scratch on my body" says the rider. But how many times do we need to see similar crashes to remember that queues of traffic frequently hide



emerging or turning vehicles - I featured a very similar crash from the UK not too long ago, but involving a car turning right from the back of the queue. [Read more](#)

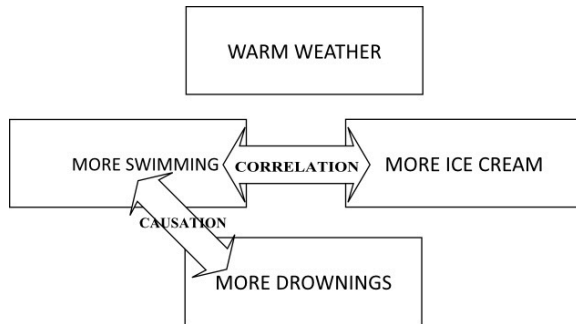

Data can't be wrong, but did we use it correctly?

This is a short series explaining the scientific method, specifically how we collect and interpret data. It's not uncommon to hear someone say: "I don't agree with

the data", but essentially that's a nonsensical statement because data itself can't be challenged. In previous articles, I've looked at how we design a study to collect data. However, not all studies are well-designed. [Read more](#)

### Turning Spidey Sense to Early Warning Radar.

Last time out I was talking about the times we get a sixth sense that something's not quite right. As I explained what appears to happen is that the brain has subconsciously identified a set of conditions experienced previously



that led to a dangerous situation developing. Whilst the actual threat remains below the level of our conscious awareness, it's usually enough to move us to a state of heightened alertness where we have a better chance of figuring out just what's alarmed us. So, last week my first tip was "trust your gut". [Read more](#)

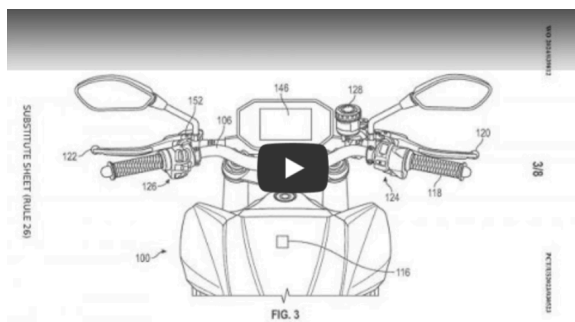

Elevenes 414 Sun 10 Mar - motorcycle news, tips & views

in today's show... court told rider with fake plates, no licence, no insurance and with drugs in his system was on a bucket list trip... bike stolen in Edinburgh returned

to German owner by Greater Manchester Police...

grenade-throwing incident prompts Phillipines city to ban full-face helmets... unusual finance offer from Ducati... US recalls for CFMoto and Livewire... in-depth today - why have Zero filed a patent for a clutch on their gearless electric bikes? [Read more](#)

---

## ***IAM RoadSmart News***

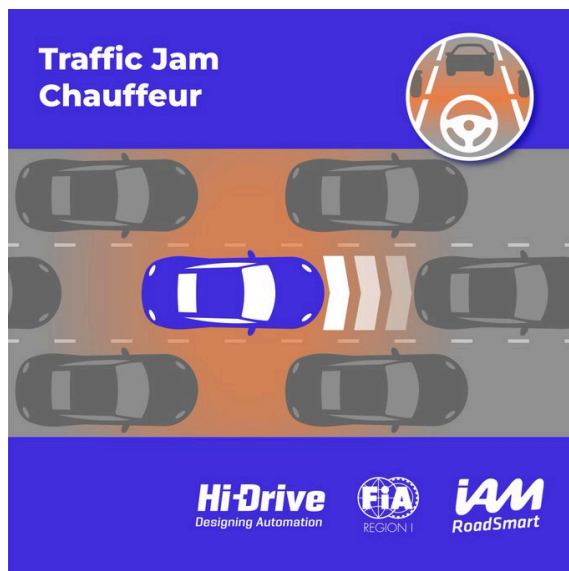

Traffic jam chauffeur (SAE level 2) monitors the speed of surrounding vehicles in slower environments of up to 60km/h.

This [#AutomatedDriving](#) function relieves drivers in traffic jams by adapting the car's speed to its surroundings.

[#HiDriveProject](#)

[#HiDriveCampaign](#)

**Want to become a better rider?** Our Advanced Riding Course can help. The roads can be a dangerous place, even for the most alert and cautious riders. While you can never be 100% safe, becoming an advanced rider will equip you with the skills to correctly anticipate, and plan for, the hazards you encounter on your rides. [Find out more](#)

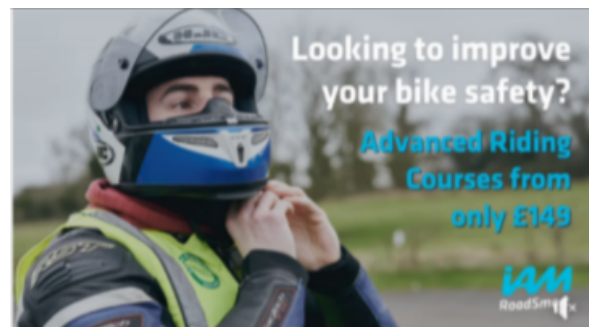

## **Other Motorcycling Organisations**

### **NMC**

The National Motorcyclists Council took part in the high-level discussions on motorcycling during the 2024 FIM Commissions Conference.



The Fédération Internationale de Motocyclisme (FIM) is the governing body for motorcycle sport and the global advocate for motorcycling. The FIM strives to apply the highest standards for health, safety and the environment in its sporting and non-sporting activities.

The 2024 FIM Commissions Conference, that ran from 16-18 February in Lyon (France), brought together 380 members of the FIM Family – including Board of Directors Members, Commissions Directors, members and experts – for three days of high-level discussions. [Read more](#)

### **FEMA**



**European Parliament: Driver Training Should Focus On Risk Awareness**

Today the European Parliament adopted new, draft rules on EU driving licences.

- No mandatory medical test will be required when a driving licence is being issued and renewed.



- The introduction of probation period for inexperienced drivers of at least two years.
- 18-year-olds can obtain a licence to drive a truck or a bus with up to 16 passengers.
- Introduction of a digital driving licence, available on a mobile phone.
- Focus should be risk awareness training.
- No higher minimum age for the A1 licence. [Read more](#)

## **BMF**



Success: Riding With A Motorcycle Trailer. Some motorcyclists like to attach a trailer to their bike. In the development of the [current driving license directive](#) the fact

that sometimes motorcycles pull trailers was not taken into account (unlike with cars). The European Parliament now agreed on new, [draft rules](#) on EU driving licences and finally fixed an oversight FEMA has been pointing out for years: the possibility to legally ride a motorcycle with a trailer behind it. [Read more](#)

---

*SAM members have you got some news to share? Send it to [sam-editor@iam-sheffield.bike](mailto:sam-editor@iam-sheffield.bike) and share it with all your SAM Club friends...*

## **Stay healthy and ride safe**

Paul Conway (on behalf of the SAM Committee) Sheffield Advanced Motorcyclists

Charity no. 1089671 IAM Group no. 4152



Saturday Meetings are for club members, observers, associates and ANY biker interested in taking an advanced rider course.

Meetings are usually for one of these purposes:

- members take the opportunity to catch up with each other and generally socialise
- observers will be taking their associates out as part of their preparation for the advanced test
- other members will form smaller groups and ride out usually for breakfast somewhere
- Bikers who want to learn about how to become an advanced motorcyclist

If you'd like to find out more about us, join us at 9am any Saturday throughout the year, at Meadowhall Retail Park, Sheffield S9 2YZ, just off J34, M1.

---

## ***Being a member of the SAM Club***

To be a member of the SAM Club we encourage you to also be a current member of IAM RoadSmart. As a registered UK charity the SAM Club has charitable objectives to encourage and support the wider use of powered-two-wheeled transport in the UK. We provide advanced motorcycle education and training to help all bikers ride more safely. Our charity has to abide by the national standards, testing and liability insurance cover to continue these

activities. Liability insurance ensures that, within the events covered, both the SAM Club, its Trustees and members are safeguarded against most untoward events. This includes all formal training and social events. Also, the SAM Club is dedicated to promoting the education and training of bikers in advanced riding knowledge and skills, both locally and nationally. At a total cost of £55/year, i.e. £1.06p/week, you help ALL your fellow bikers to improve their riding knowledge and skills. Thank you.

---

**Associates:** SAM's highly trained, dedicated, self-funding, volunteer Observers, meet all their own expenditure in providing your training. When you go out on observed rides with your Observer, we are asking you to donate £10 to offset a little of their running costs in helping you to become an advanced motorcycle rider. Thank you.

### ***Extra bits***

- Next SAM Committee Meeting: **27th March 2024 - 7.30pm on Zoom**
- Next SAM Club Night: **8th April 2024 meet at 7.30pm for an 8pm start** [Treeton Miners Welfare, Arundel St, Treeton, Rotherham S60 5PW, UK](#) **ANNUAL GENERAL MEETING**
- **Gift Aid Form:** Gift Aid allows UK charities to claim back the basic rate tax already paid on donations. This means we can claim back from the government on your behalf 25p for every £1 donated, boosting the value of the donation by a quarter. Use this link to fill in the form on the SAM website and send it to [treasurer@iam-sheffield.bike](mailto:treasurer@iam-sheffield.bike).
- **Not getting your SAM emails?** If any member is NOT getting SAM Club emails, first check your junk folder, then send a request to [social-media@iam-sheffield.bike](mailto:social-media@iam-sheffield.bike). Pass on this message to any members who are complaining about not getting their SAM Club emails.

- **Changing your email address:** If you change your email address then let the Social Media Secretary - [social-media@iam-sheffield.bike](mailto:social-media@iam-sheffield.bike) - know so that we can keep you informed of all the exciting things happening in your club.
  - **IAM RoadSmart member discounts:** SAM members, are you making the most of your IAM RoadSmart membership? There are lots of discount savings that can offset your IAM RoadSmart and SAM membership fees, so grab a bargain TODAY!
  - **Share with your friends:** Know someone who is interested in biking? Why not share this SAM Update and help them to be an advanced rider.
  - **Follow us on** [Facebook](#), [Twitter](#) & [Instagram](#).
- 

## ***What are we about...***

*The Sheffield and District Advanced Motorcyclists (SAM) are an independent charity that provides public education and training in advanced motorcycling skills. Its aims are to increase public awareness and understanding of motorcycling and the advanced knowledge and skills required to ride safely on public roads. It is an affiliate group of the Institute of Advanced Motorists (IAM RoadSmart) and works closely with statutory and non-statutory organisations in promoting public information and education on motorcyclists and motorcycling in its designated region. SAM's volunteer motorcyclists are all trained to and maintain national standards of advanced motorcycle riding. They provide ongoing guidance and support to prepare motorcyclists for UK nationally recognised advanced motorcycling tests. SAM works closely with other charitable groups who require advanced motorcyclists to support public events, NHS dispatch rider services and many other socially responsible activities. SAM provides an essential public service in encouraging, promoting and marketing improved safety on public roads in the UK and internationally through IAM RoadSmart. SAM also has a very active social events*

*programme that encourages its members, family, friends and the public, to both support the charity's socially responsible objectives and enjoy the camaraderie and support provided by the club.*

## **Club Merchandise**

***"YOU can proudly support YOUR Club"***

---



Clothing can be ordered online direct from:

**APRINT LTD**

138 Morthern Road

Wickersley

Rotherham

S66 1EA

Telephone: 01709 709977

Fax: 01709 709987